



DOUGLAS
WASHING AND SANITIZING SYSTEMS

OPERATION & MAINTENANCE MANUAL

RACK WASHER

Digital Controls



Parts & Service 800-331-6870

DougMac.com

We congratulate you on the purchase of your new Washing and Sanitizing System. To understand the proper operation and maintenance of your new machine, please read this manual carefully. A Reference Guide is mounted on the side of the machine for your convenience. You have also received a Recommended Installation Guide. Please review this guide and confirm that the machine has been installed correctly.

If you have any questions or need any further information, now or in the future, please do not hesitate to contact us.



DOUGLAS

WASHING AND SANITIZING SYSTEMS

4500 110th Ave N,
Clearwater, FL 33762
(727) 461-3477
(800) 331-6870
Fax: (727) 449-0029
DougMac.com

Please Note: Specifications are subject to change without notice
This book is a publication of Douglas Machines Corp. Service Department.
Future editions will reflect changes in procedures or technical details
Use and duplication of this document is encouraged.
For technical assistance, please call
800-331-6870.

© Copyright Douglas Machines Corp.

SAFETY

Qualified installation personnel, individuals, firms, corporations, and companies are responsible for:

- Wear appropriate P.P.E., ie... hearing protection, thermal resistant gloves, and eye wear.
- Know where the **exits** are located.
- Always turn off and drain the machine before entering. Allow a cool-down period. Follow facility's L.O.T.O. procedures.
- **Never** enter a machine where the flooring has been removed.
- Fall Hazard.
- Use non-permit required confined space guidelines for entering.
- When loading a rack into the washer keep hands away from the door edges. Keep hands on the horizontal bars inside of the rack. **Do Not** hold racks on the vertical support bars or outside edges. Push the rack with both hands. **Never** strain yourself to move a rack. If the racks are too heavy, unload some product.
- **Always use caution.** - Use mats to reduce slip hazards.
- Ensure that the float switches and level probes are well maintained and cleaned daily. Failure to do so can result in unintended heater start up and potential fire.
- **Never** leave your machine idle (not in use) for more than four hours. This can cause water to evaporate from the machine resulting in damage.
Do not touch the rinse tank without a cool-down period.

CONTENTS

Delivery	5
Pre Installation.....	5
Best Practices	6
Safety Precautions.....	7
Start Up.....	8
Digital Touch pad Controls.....	11
Programming	12
Operation	14
Docking Cart (If Equipped)	16
Maintenance.....	18
Reset the PC Board.....	20
Troubleshooting:	21

DELIVERY

- Inspect the machine for any external damage. Any evidence of damage should be noted on the delivery receipt and signed by you and the driver.
- Remove packaging from the washer and check for any concealed damage. Carrier must be notified of damage immediately. Please retain packaging for inspection if claim is filed.
- Douglas Machines Corp. cannot accept responsibility for lost or damaged merchandise suffered in transit. The carrier assumes full responsibility for delivery in good order, however; we are prepared to assist you in any action needed regarding shipping damage.

ELECTRICAL CONNECTIONS: Upon receiving your machine, all wire connections in the electric panel, pump motor and electric heaters should be checked, including the wire nuts and lugs. Check connections monthly for the first six months and every 90 days after the first six months of operation.

IMPORTANT

PRE-INSTALLATION

Qualified installation personnel, individuals, firms, corporations, and companies are responsible for:

- The installation or replacement of the gas piping and connection, installation, repair, or servicing of the equipment. Qualified installation personnel must be experienced in such work, familiar with all precautions required, and have complied with all requirements of state or local authorities having jurisdiction. Reference National Fuel Gas Code, NFPA 54 or latest edition or ANSI Z223.1 or latest edition, Section 1.4.
- The installation of electrical wiring from the electric meter, main control box, or service outlet to the appliance. Qualified installation personnel must be experienced in such work, familiar with all precautions required, and have complied with all requirements of state or local authorities having jurisdiction. Reference National Electrical Code, ANSI/NFPA 70 or latest edition. In Canada, Canadian Electrical Code Part I (Std. 22.1 or latest).
- The installation of gas heated units in Canada. Qualified installation personnel should comply with the Installation Codes for Gas Burning Appliances and Equipment, (CAN-I-B 149.1 and B-149.2) and any local codes or approvals.
- The installation of washers equipped with casters. These washers shall be made with a connector that complies with the Standard for Connectors for Movable Gas Appliances, ANSI Z2 1.69 or latest, and a quick-connect device that complies with the Standard for Quick-Disconnect Devices for use with gas fuel, ANSI Z2 1.41 or latest.
- Water and waste piping and connections shall comply with the International Plumbing Code, International Code Council (ICC) or the Uniform Plumbing Code, International Association of Plumbing and Mechanical Officials (IAPMO). NSF/ANSI 3-2009

BEST PRACTICES

DO'S

- Before attempting any maintenance or repairs, ensure that electrical supply to the unit has been turned off and locked out.
 - Wear safety glasses.
 - Check inside the unit before starting the cycle to ensure nothing is inside.
 - Keep hands and clothing clear of moving parts.
 - Ensure safety rules are followed at all times.
 - Ensure all electrical panel enclosures are closed before using the machine.
-

DO NOT

- Attempt to perform any maintenance, repairs or adjustments unless the supply power has been shut off and locked out first.
- Open door during machine cycle. There may be a delay between cycle steps so ensure cycle is complete by visually checking that the Run light is not illuminated.
- Hose down any electrical components.
- Remove any access panels or pit grids while unit is in use.
- Touch outside of cabinet without wearing gloves.
- Attempt to do any service or make any adjustments to this unit unless you are qualified service person.

SAFETY PRECAUTIONS

IMPORTANT: All safety precautions must be adhered to as to avoid personal injury.
PLEASE BE CAUTIOUS!

- Minimum P.P.E. equipment to be used when operating or maintaining this equipment is safety glasses, hearing protection, and heat resistant gloves.
- When using the spray off gun, please be cautious of potential hot water hazard. Do not spray in the direction of yourself or any other personnel. Only use for maintenance of the machine.
- If machine is in “Wash” mode and stopped, allow 3 second ramp down time for spray arms before opening machine door.
- Machine must be installed keeping in mind clearance for maintenance and in accordance with facility high foot traffic areas, railings, and any areas where a hazard could be created.
- Visibility should also be considered eliminating any blind corners, stairways, or drop offs in the general area.
- When removing the filters of the machine for maintenance of any kind, the machine **MUST** be turn off, drained, and lock out and tag out procedures followed. Proper fall hazard procedures must also be followed.

EMERGENCY EGRESS

All machines are equipped with an interior door release to enable the opening of the door should it close while someone is inside the machine. The release is pressed which releases the latch and allows the door to open.

NOTE: Figure to the bottom shows the internal door release latch. **All operators should be aware of this feature and how it works.**

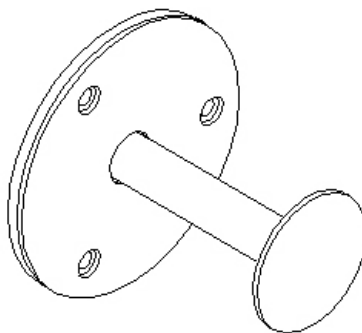

Internal Door Release - Push to release

START UP

IMPORTANT: Remember where your electrical disconnects are located.

Note* - All machines leaving the USA will be single point connection. Some of the following steps will be performed in the electrical panel enclosure. We recommend disconnection of all incoming power before doing any service in the electrical enclosure. Please Be Cautious!

- Disconnect incoming electrical power, open the enclosure door located at the side or rear of the machine. Turn all thermostats to the lowest or off position (turning knobs in the counterclockwise direction).
- Locate and make sure the drain valve is in the closed position.
- From inside the machine remove the plastic wire tie on the float switch.
- Shut off all breakers going to the heaters, if electrically heated. Breakers will be marked WASH HEATER and RINSE HEATER. If machine is fitted with fuses and fuse holders, use appropriate disconnecting means to safely de-energize the wash and rinse heating circuits.
- With the electrical enclosure panel cover still open, turn the incoming power back on. Make sure the circuit breaker or fuse holder marked "PUMP" and circuit breakers or fuse holders marked "120v" are in the on position (BE VERY CAUTIOUS - THIS IS NOW AN ELECTRICALLY LIVE PANEL).

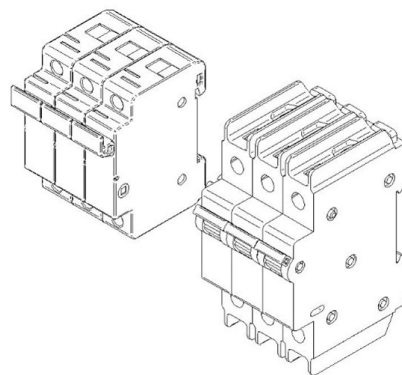

Left: Fuse Holder Right: Circuit Breaker

- Press the Power button and release it. At this point the machine will start to fill and continue until the water level reaches the overflow drain, which can be identified by a “Mushroom” shaped cap located in the interior table of the wash cabinet. If it does not fill to the overflow drain, reprogramming of the auto fill may be necessary (refer to section “Programming the PC Board”)
- You must also make sure the incoming water pressure is at a minimum 20psi (138 kPa) flow pressure not exceeding 30psi (207 kPa) flow pressure with a static pressure not exceeding 60psi (414 kPa) as stated in the Recommend Installation Guide.

NOTE: Incoming water pressure exceeding 30psi (207 kPa) flow will void warranty on related items.

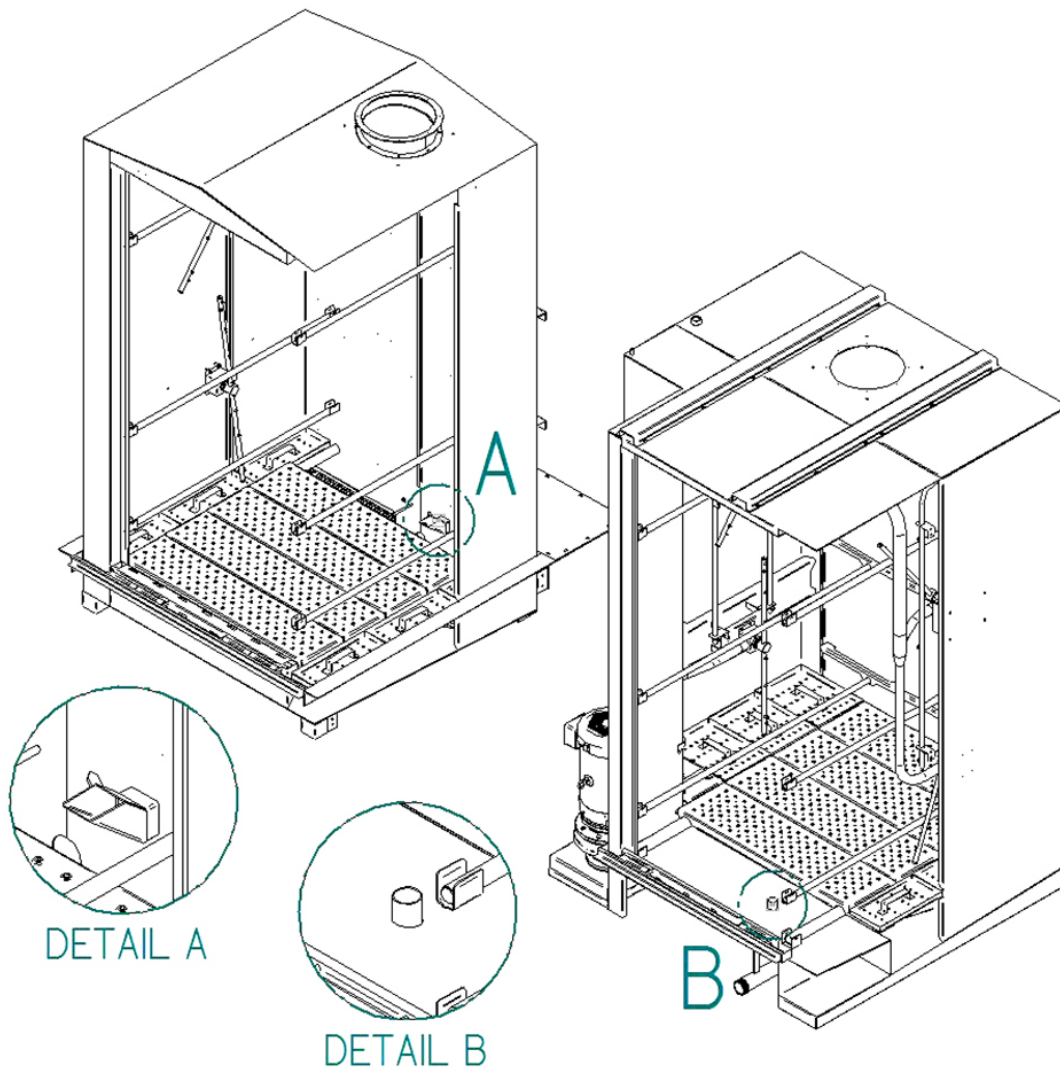

General Overflow Location – “DETAIL A” shows typical location for models ending “B” or “SPW” – “DETAIL B” shows typical location for all other rack washers

- Press the "Short Wash Cycle Button"; the wash pump should start running at this point. If the pump does not start running, check all fuse (if applicable), and all breakers marked "PUMP" and "120v" are in the on position. With the pump running, check the pump rotation looking at the rear of the pump motor and observe the cooling fan to see if it is rotating clockwise. Another indication that the pump is rotating backwards is the wash pump pressure gauge reading under 35psi (241 kPa). If the pump is not rotating in the correct direction, reversal of electrical phases will be necessary. (Contact your electrician or Douglas Machines Corp. for details.)

To fill the rinse tank, push the "Short Button"; the machine will now run through a complete cycle. A complete cycle entails a four, six, or eight-minute wash time depending on the cycle selected. During this time, the wash pump will be active. Followed by a 30 second rinse time in which the pump will be inactive and the rinse solenoid valve is open. And finally, a one-minute dwell and steam extraction time in which the machine cannot be restarted until this time has expired. Repeat the cycle two more times to ensure the rinse tank is full.

PLEASE NOTE: While the machine is in the "Rinse" and "dwell" period you will not see any readings on the jet pressure gauge, as the rinse cycle operates strictly off the incoming water pressure to the machine, not the wash pump. The pressure readout for the supply water is located above the machine in the incoming water supply circuit.

Failure to ensure the rinse tank is full of water may result in damage to the tank and heating components and may void the warranty of related items. Double check to ensure all heating circuits are off!

To ensure the rinse tank is filled, you need to hear water spraying inside the wash cabinet after the wash pump has stopped running. You may need to run more than one cycle to accomplish this.

CAUTION: Before proceeding to the next step, make sure you can hear water spraying in the cabinet after the wash pump stops running and the rinse light cycle is illuminated. If not, heater damage may occur, and the warranty will become void for related items.

- Now it is time to set the thermostats. We are looking for an idle wash tank temperature of 160 °F (71°C), and during operation a temperature of 150 °F (66°C). The rinse temperature should be set to read 190°F (88°C) temperature. Turning the thermostat knobs in a clockwise motion and using top dead center as our indicator, increase the thermostat marked "WASH" to 160°F (71°C). Increase the thermostat marked "RINSE" to 190°F (88°C). Switch the "WASH HEATER" and "RINSE HEATER" breakers or fuse holders to the on / energized position. Allow 30 to 60 minutes for the machine to reach operating temperatures.

NOTE: There can be as much as 12 °F to 15 °F difference between the thermostat and the temperature gauge. Always set the thermostats to accommodate the desired temperature using the front panel gauges as your guide. For Machine and Operator Safety DO NOT set Wash or Rinse water temperatures above 190 °F (88 °C).

- Your heat source should be engaged. If electrically heated, the wash and rinse heater contactor will be engaged. If gas heated, the burner or burners will fire. If steam heated, the steam solenoids will open. If you are not sure, or if the specific heat source is not on and the unit is not heating up, please refer to the Trouble Shooting Guide or contact Douglas Machines Corp. for assistance.
- When everything is working fine, close and lock the electrical enclosure panel and start washing.

DIGITAL TOUCH PAD CONTROLS

The Digital Touch Pad (Part # 10791) and PC Board (Part # 10792). The basic function of the board is to control the operations of the unit, going through a cycle of Wash, Rinse, and then Fan (Dwell). The Touch Pad display shows cycle countdown time and error codes. These instructions include how to program the control and describe the various timing ranges that can be set in programming, the default times, the error codes, and the specifics of what the readout will show during the various modes of operation and programming.

DUAL FUNCTIONS OF FRONT PANEL BUTTONS

NORMAL MODE FUNCTION	PROGRAMMING MODE FUNCTION
Short	Toggle
Medium	Down
Long	Up

In normal operation, a set chain of events completes a cycle.

- Start the machine and light the display. Push the "Power Button". The display flashes 00:00 until water touches the sensor.
- The display will stop flashing and the "Fill Time" will start to count down.
- Wait for the machine to fill. The wash heater is on anytime water is in contact with the sensor.
- When "Fill" is complete, the digital screen will read 00:00 and the machine waits for a "Wash" selection. Fill does not stop if the door is opened during the "Fill Cycle".
- Select desired Wash cycle: Short, Medium, or Long. Display shows preset wash time.
- The "Wash" indicator light will come on when the wash cycle starts.
- The display counts down from the preset wash time.
- When the Wash Cycle ends the Rinse Cycle will start. The display shows rinse time remaining and begins the countdown. The rinse light should be lit.
- The Rinse Cycle times out when the buzzer beeps 3 times, or until the "Stop Button" is pushed, or the door is opened.
- Make sure that the auxiliary output relay on the main board closes for 3 seconds, the exhaust fan comes on, the display shows the "Unload Time", and begins the countdown.
- Make sure the "Unload" light is lit.
- Make sure the display reads 0:00 and waits for a wash cycle selection after the "Unload" times out and all lights go off.

NOTE: A short “beep” sounds any time an appropriate button is pushed, thereby giving an audible as well as a tactile feedback to the operator. Once a machine cycle begins, only the Power and Stop buttons will function. Opening the door or an interlock trip will act as a "Stop" and will cause an error code to appear on the display.

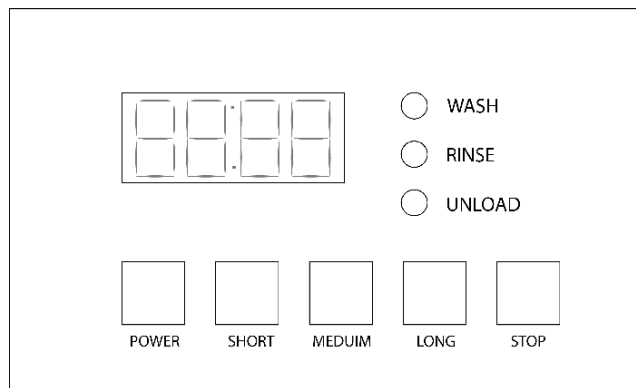

Digital Control Panel

PROGRAMMING

- Before starting, make sure that the 120 volt circuit is turned on, there is no water in the wash tank, and that the drain valve is closed.
- With the control voltage on, the colon on the touch pad display will be illuminated and flashing.
- In order to make a programming change other than to the Auto Fill, fill the machine with water. Failure to do so will require starting with programming the Auto Fill and then proceeding to make the desired function change.
- To initiate programming, press and hold the "Stop Button" and then the "Power Button", holding both buttons at the same time until a beep sounds and four 0's (0.00:0) appear on the display.
- Wait until the machine automatically fills with water and the reaches the sensor.
- Begin the programming. The programming for the fill of the wash tank is the only function that needs to be programmed. All other functions are factory preset.
- To program the Auto Fill, press the "Long Cycle" button. The Fill process starts and the display timing begins.
- After water level has reached the overflow, press the "Medium Cycle" button. The flow of water stops and the time is displayed.
- To enter the programmed time into the PC board, press the "Short Cycle" button.
- After programming the Auto Fill, press the "Short Cycle" button to scroll through the remaining functions, either to exit the Program Mode or to make any changes to the following functions.

DIGITAL TOUCH PAD NORMAL SETTINGS

FUNCTION	TIME	
	MINUTES	SECONDS
Auto Fill	Variable	
Heater Delay		15
Heater Delay	4	
Medium Wash Cycle	6	
Long Wash Cycle	8	
Rinse		30
Dwell and Fan	1	

- To exit the Program Mode, scroll through remaining functions or press the "Stop" button for 2 seconds.

NOTE: The settings on these functions can be changed while viewing the preset times.

- To decrease the time, press the "Medium Cycle" button, and then press the "Short Cycle" button to enter the change.
- To increase the time, press the "Long Cycle" button, and then press the "Short Cycle" button to enter the change. If an error code is present in the display, it must be identified, resolved, and cleared from the PC Board.
- To clear error codes from the touch pad display, press the "Stop" button.

OPERATION

With the machine turned on, filled to the overflow, and heated up to the correct operating temperatures, we will now be able to add detergent.

A non-foaming, non-caustic, aluminum safe type of soap must be used (unless the machine has been specifically manufactured for caustic use). Machines without a caustic upgrade package are designed to work with a chemical solution within a PH range of 5 - 9.5. Use of chlorine or bleach will void warranty, please contact Douglas Machines Corp. to determine what chemistry your machine is capable of running.

If the machine is fitted with an automatic soap dispenser, ensure the dispenser is turned on and filled up. If the machine is not equipped with an automatic soap dispenser, follow your detergent manufacturers' recommended specifications for application and concentration.

NOTE: Douglas Machines Corp. recommends the machine be operated with an automatic detergent dispenser equipped with a visual or audible alarm means to verify chemicals are being dispensed.

GENERAL OPERATION

- When loading the machine with bowls, buckets, or any similar type of object, all items should be facing the wash arms. The racks are pitched so that open end of the product should be facing down. Use of the "hold down" gate may be necessary for lighter products.

When loading sheet pans into a sheet pan rack, you will notice that the sheet pan rack is built with angled pan supports. Load the rack so that the face or open side of the sheet pan is facing towards the door of the unit.

If you are planning to wash cake pans and have purchased a cake pan rack, you will need to load the cake pans into the area built on the outside of the rack. The cake pans will need to be loaded with the open side of the pan facing out towards the wash arms. Some racks are adjustable to accommodate the depth of the cake pan.

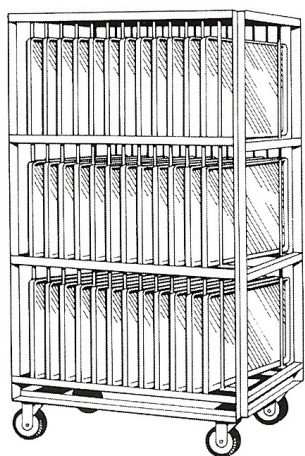

Sheet Pan Rack

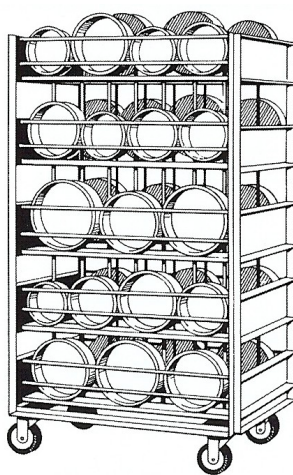

Cake Pan Rack

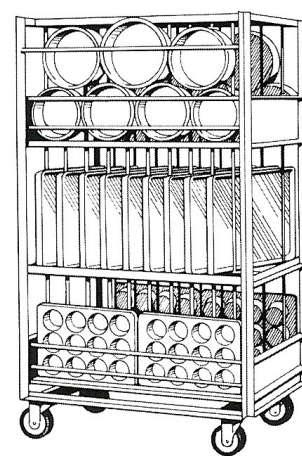

Combination Rack

If you are planning to wash smaller utensils, such as spoons, scrapers, and whisks, you will need to purchase a model specific utensil basket (contact Douglas Machines Corp. for details).

Scale Parts can also be loaded on specific scale parts racks. These racks are commonly adjustable for various sized scale heads. “Feeder Pans” should be placed on the top of the rack at an angle on the angled feeder pan section. The “Hoppers” or “Weigh Buckets” should be placed on the holding rods with bottom of the hopper open towards the inside of the rack.

NOTE: Always push racks into the machine with hands placed on the inside cross members of the rack. **DO NOT PUSH RACK INTO MACHINE WITH HANDS ON OUTSIDE VERTICAL COLUMNS OF THE RACK. DO NOT OVERLOAD THE RACK. IF THE RACK IS TOO HEAVY REMOVE SOME PRODUCT.**

- Once filled, the machine should be allowed to sit and reach operating temperatures before washing. This could take anywhere from 30-60 minutes. Add detergent and load. (See previous steps in General Operation). It is now time to start washing! Choose your desired wash cycle time by selecting the short four minute cycle, medium six minute cycle, or long eight minute cycle. Let the machine run through its entire cycle (wash, rinse, and dwell). If you open the door or hit the stop button any time during the cycle, the machine will shut off. When you restart the machine, it will not start from where it stopped, it will start from the beginning of the wash cycle. At this point you will be able to unload and then reload the machine.

NOTE: If machine is in “Wash” mode and stopped, allow 3 second ramp down time for spray arms before opening machine door.

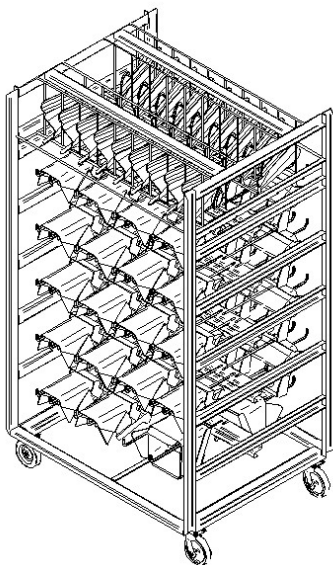

Scale Parts Rack

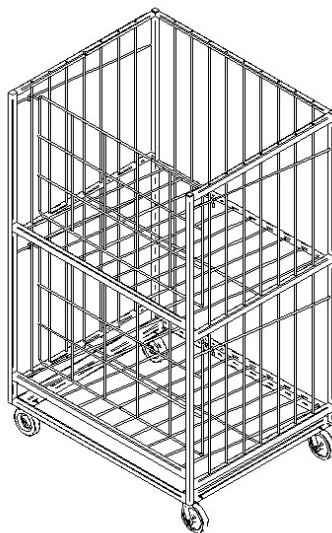

Empty Rack

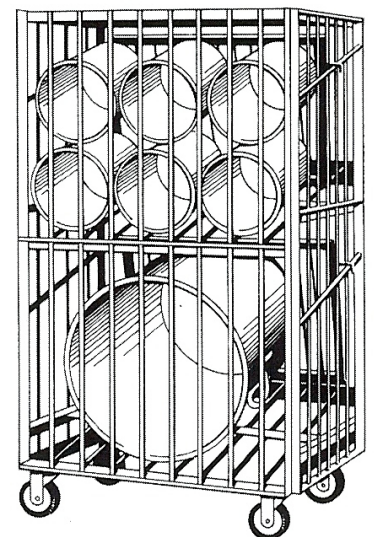

Pot and Utensil Rack

DOCKING CART *(If Equipped)*

The docking cart is designed to transport the machine wash racks and allow easy loading of the rack without the use of ramps or a machine pit. The docking cart docks to the front face of the machine and can be secured with a hook ring type latch.

SEQUENCE OF OPERATION

- Load empty wash rack onto docking cart.
- Secure wash rack hook clamp.
- Load product in wash rack.
- Transport wash rack / cart to open ready machine.
- Dock cart to machine and secure Hook Docking Latch.
- Release wash rack "Hook Clamp".
- Roll wash rack into machine and close door. Run Cycle.
- Open the door when washing as finished.
- Roll wash rack out of machine onto Docking Cart.
- Secure wash rack Hook Clamp.
- Release Hook Docking Latch from machine.
- Remove rack / cart.
- Close machine door.

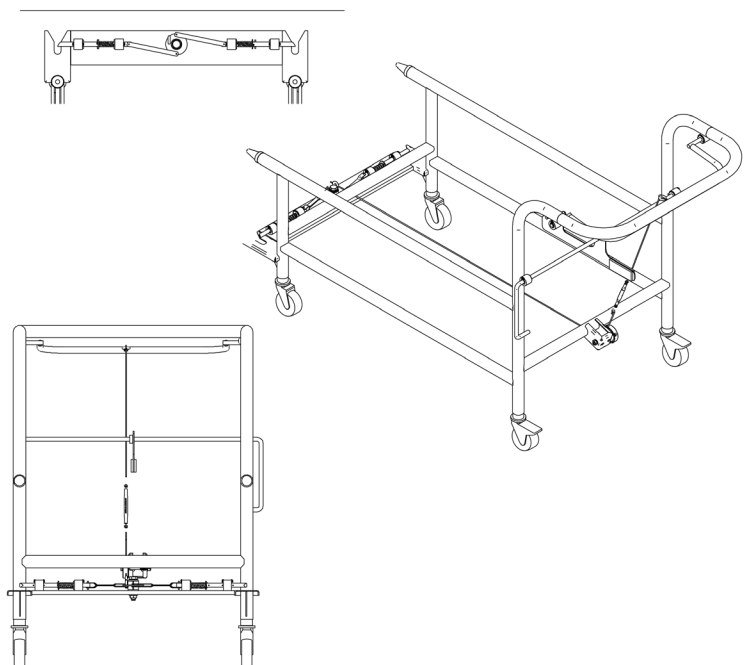
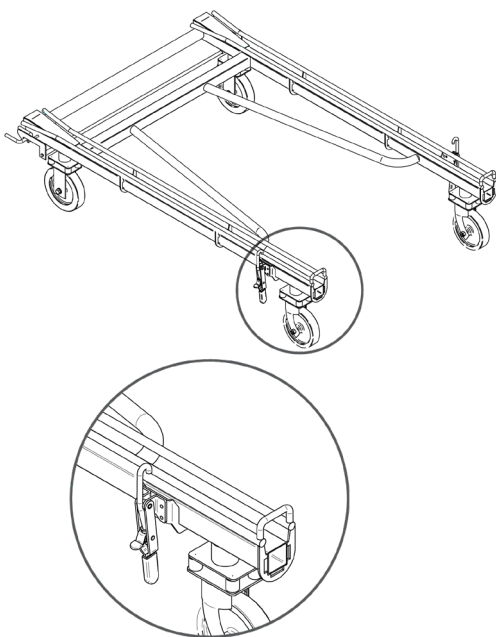

MAINTENANCE

As a precaution, you must disconnect or turn off all incoming power to the machine before proceeding with any maintenance.

DAILY MAINTENANCE

Regular maintenance is essential in keeping your machine in good working order and operating at maximum efficiency. The following maintenance items are a minimum requirement. Frequency of maintenance is dependent on the number of hours the machine is in use and the amount and type of soil being removed.

These daily maintenance items need to be done at the end of a regular shift, or if the machine is not cleaning to its normal standards.

- Drain the machine by locating the manual gate valve to help determine what your machine is equipped with. The machine should never be drained or cleaned unless the power is in the "OFF" position. A cool down period should also be allowed before cleaning. If the machine is equipped with a motorized drain valve or pumped drain, ensure the machine is turned "off" on the front panel, then turn the drain open / close or on / off switch to the open / on position.

NOTE: the electric drain valve will only operate when the power on the front panel is in the off position, to ensure the valve is never opened during operation.

After the machine has been drained, you must disconnect / turn off all incoming power to the machine before proceeding with any maintenance.

- Use the Spray Off Hose to direct all debris into the filter baskets.
- Remove and clean the filter baskets and floor panels.
- Scrub and rinse the wash tank reservoir.
- Spray down the inside of the wash cabinet.
- Inspect the drain and overflow drain to ensure they are draining properly.

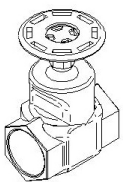

Manual Gate Valve

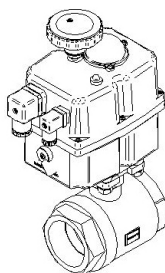

Motorized Drain Valve

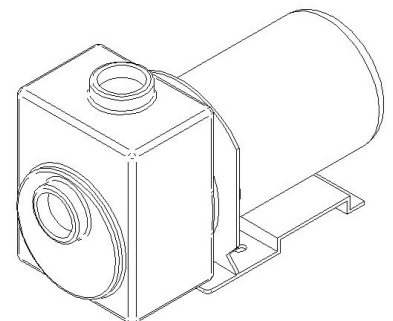

Pumped Drain

- Direct all remaining debris into the open drain located in the bottom of the reservoir tank. If your machine is equipped with a pumped drain you will need to remove the debris by hand. Flushing the debris down the pumped drain pump may cause clogging.

Your machine will have either be equipt with two liquid level float switches or 1 metal bottom liquid level probe.

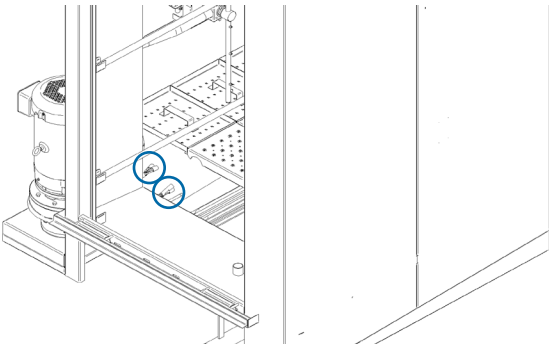

Front Pumps Float Locations

Remove front floor panel and pump side filter basket

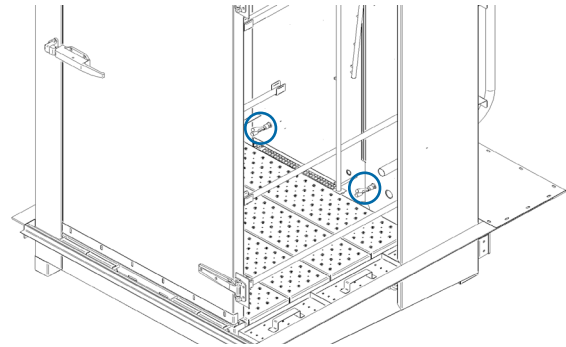

Rear Pump Float Locations

Remove back floor panel and pump side filter basket

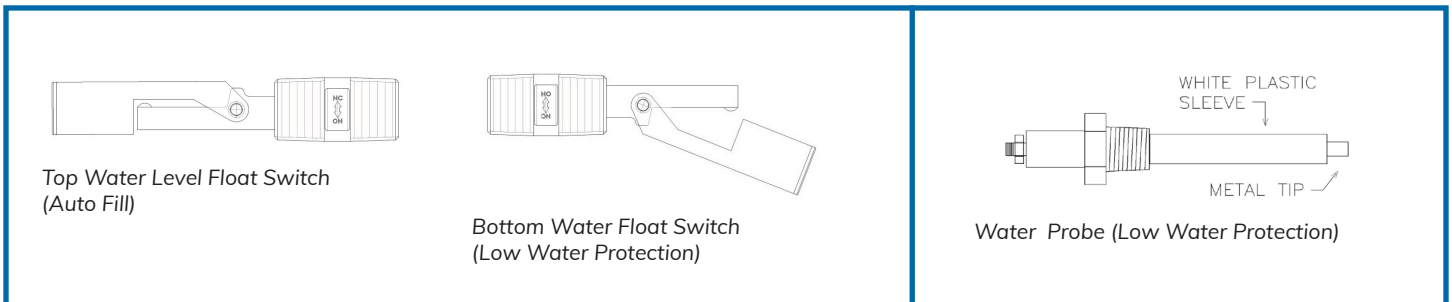

- Clean both the Water Level Float switches or probe. Clean the entire float switch if your machine is equipped with floats. If equipt with a probe clean the metal tip of this probe with some a scouring pad.

Remove all scale and residue. Failure to do so may cause the heating source to remain on with no water in the reservoir, damaging heating components and may void warranty to related items. If your machine has an electric heater or heaters in the wash tank, it is now time to clean them. The heater coils will be located directly under or near the low water probe. Use a wire brush or scouring pad to clean the exposed heating coils on the heater or heaters. Direct all debris into the drain.

- Clean and scrub the electric heating elements located within the wash tank (if applicable).

The heater coils will be located directly under or near the low water probe. Use a wire brush or scouring pad to clean the exposed heating coils on the heater or heaters. Direct all debris into the drain.

When the wash cabinet, filters, wash tank reservoir, low water sensor, and electric heater or heaters (if applicable) have been cleaned, you can put the flooring and filters back in place.

- Inspect all the spray jets. Look for any that might be missing, obstructed, or worn out. If you find any missing or worn out jets, contact Douglas Machines Corp. for a replacement. If you find any jets obstructed, try to remove the obstruction by pulling it out or by forcing it back into the jet pipe. If you need to force it back into the jet pipe, you will need to remove the jet pipe end cap to remove the obstruction from the pipe.
- Clean the outside of the machine. Use a stainless-steel cleaner or a mild detergent and a soft cloth to wipe down the outside of the machine.
- Close the drain valve and assure that the filters and floor panels are back in place.
- Reconnect the main power.
- Turn the machine back on and allow it to fill and come back to operating temperature.
- The machine is now ready for use.

DO NOT turn on the main power until you are ready to resume washing again.

NEVER leave the machine "On" for longer than four hours between running cycles. Damage to the rinse components and or tank could occur.

PERIODIC MAINTENANCE

- Wash pump motor lubrication. You will find two grease fittings on the top of the wash pump motor and one at each end. You will need to grease these under normal conditions every 90 days. Use an electric motor bearing grease like Shell Dollum or Chevron Sill.
- If you have purchased the steam extraction option, you may need to grease the 12" steam extraction fan bearings.

NOTE: Some of these fans are equipped with sealed bearings and do not require greasing. You will need to determine if your fan is equipped with the sealed bearings or if the bearings will need to be greased. Refer to your parts manual to identify the steam extraction fan and the grease fitting location. If greasing is required, it should be performed every 90 days. Use high temperature food grade grease such as Sentinel Slth #2.

- The removal of lime and or scale may be necessary at certain times. This will vary due to the condition of your water. If you are finding lime and scale building up on the interior walls of the machine, chances are they are also building up in the piping. This could impair washing ability. You will need to use a lime and scale removal chemical. Whatever you decide to use, be sure it is safe to use on stainless steel, bronze, and brass. If you have any questions on what to use or how to use it, do not hesitate to contact Douglas Machines Corp.
- The Solenoid Valves should be checked periodically to ensure they are in good working condition, solenoids have a life span of about 1 million cycles.

RESET THE PC BOARD

Power down the digital display (colon illuminated only). Press the "Stop" button and hold it. Then press the "Short Cycle" button and hold them both in at the same time. You will hear a beep, the unit will revert to the default times. The Auto Fill Time will not be affected.

CONNECTION TABLE FOR 10791 BOARD

FROM JACK #	TO WIRE #	BOARD MARK	PURPOSE
J10-1	Black	Left to Right	10-14 VDC
J10-2	Red		10-14 VDC
J10-3	Blue		Communication
J10-4	Brown		Communication
J10-5	Orange		Communication
J10-6	Yellow		Communication
J10-7	White		Communication
J2-1			Not Used
J2-2	*	LV	Liquid level detector / Float Switch
J2-3	*	WS	Wash pump contact coil
J2-4	*	RS	Rinse solenoid valve/rinse pump contact coil
J2-5	*	DS	Door switch
J2-6	*	OV	Motor overloads
J2-7	*	L2	AC line (neutral)
J2-8	*	L1	AC line (hot)
J2-9	*	L1	AC line (hot)
J3-1	*	WT	Power to wash thermostat
J3-2	*	FL	Auto fill solenoid
J3-3	*	RT	Power to rinse thermostat
J3-4	*	AD	Power to auto drain switch
J3-5	*	FN	Steam exhaust fan
J3-6	*	AL	Power to optional bell

NOTE: See Electrical Drawing.

**CONNECTION TABLE FOR 10791 TOUCH PAD
J3 WIRING CONNECTIONS FACING DOWNWARD**

FROM JACK #	TO WIRE #	BOARD MARK	PURPOSE
J3-1	Black	Left to Right	10-14 VDC from PC Board
J3-2	Red		10-14 VDC from PC Board
J3-3	Blue		Communication
J3-4	Brown		Communication
J3-5	Orange		Communication
J3-6	Yellow		Communication
J3-7	White		Communication

TROUBLESHOOTING:

TOUCH PAD ERROR CODE VALUE TABLE

ERROR CODE	INTERPRETATIONS
Er01	The machine has exceeded the allowable fill time, indicating low incoming water pressure or that the drain valve has been left open.
Er02	The "Stop" button has been pressed during the Wash Cycle.
Er03	Excessive water loss occurred during operation.
Er04	Control board error has occurred. Reprogramming may be required.
Er05	Operation of the machine has been attempted without adequate water in the wash tank.
Er06	Door has not closed properly.
Er07	Pump overload device has been tripped.

LIGHT AND DECIMAL POINTS DURING PROGRAMMING MODE

CYCLE	INDICATOR	TIME	
		ON	OFF
Auto Fill	Displays 0.0.00 before water hits Low Water probe. Displays 0.0.00 and counts up after water hits Low Water Float Switch.	N/A	N/A
Delay (heater)	Flashing colon	.5	.5
Short Wash	Wash Cycle light and first decimal point flash	5 sec.	5 sec.
Medium Wash	Wash Cycle light and fourth decimal point flash	5 sec.	5 sec.
Long Wash	Only the Wash Cycle light flashes	5 sec.	5 sec.
Rinse	Rinse Cycle light	On	On
Unload	Unload light	On	On

**PROGRAM MODES AND DEFAULT TIMES
TROUBLESHOOTING TABLE FOR 10791 PC BOARD**

PROBLEM	LIKELY SOURCE OF PROBLEM	CORRECTIVE PROCEDURES
Wash pump will not start.	Door	<p>If Error Code 06 is shown on the touch pad, it indicates that the door is open. Make sure the door is closed.</p> <p>Ensure the door is not directly contacting the door switch, or is within 1/8" of the switch.</p> <p>The Prox switch could be bad or the door Interlock switch is engaged. (Depends on the machine)</p> <p>Temporarily jump out connection in PC Board.</p>
	Keyed Door Switch	<p>If your machine is equipt with a keyed door swtich ensure that the key is fully engaged into the switch.</p>
	Pump motor over-load	<p>If Error Code 07 is shown on the touch pad, it indicates that the motor over-load has tripped or motor starter. (Depends on the machine)</p> <p>Try pressing the "Reset" button on the overload (blue button, located in the electrical panel).</p>
	Pump circuit breaker	<p>If the circuit breaker for the pump motor is tripped, reset the breaker or motor starter. (Depends on the machine)</p>
	Pump motor fuses	<p>Check all fuses in case any are blown.</p>
	Water	<p>Ensure that water is in the tank.</p> <p>The low water protection component may be preventing the Wash pump from running.</p> <p>If there is water in the tank and the pump motor will not start, the Level Float may not be sensing the water. Error Code 05 on the touch pad indicates that the Float Switch is not contacting the water.</p> <p>Clean Float Switch.</p>

TROUBLESHOOTING TABLE FOR 10791 PC BOARD (CONTINUED)

PROBLEM	LIKELY SOURCE OF PROBLEM	CORRECTIVE PROCEDURES
Machine will not go into Rinse cycle.	Door	<p>Make sure that the door is closed.</p> <p>Make sure the Door Interlock Switch is Engaged or that the Prox switch is within 1/8" of the door. (Depends on the machine)</p>
	Rinse solenoid	<p>Verify that the Rinse Solenoid is being energized when the Wash Cycle times out.</p> <p>Refer to Troubleshooting the Rinse Water for more info.</p>
	Rinse LED	The Rinse Cycle LED should be illuminated on the touch pad.
Machine will not fill	Water	<p>If the machine is empty and the touch pad displays an illuminated and flashing colon, the machine will fill with water by depressing the Power button.</p> <p>If the machine will not fill, the Float Switch may be dirty. Clean the Float Switch.</p> <p>Check that the LED for Relay D-16 is illuminated.</p>
	Water pressure	<p>If the Wash Tank does not fill completely, check for changes in the water pressure in the building.</p> <p>Fill Cycle is timed and it can be affected by abnormal water pressure.</p> <p>Fill Cycle time may need to be reprogrammed.</p> <p>Proper water pressure to the machine is 60 psi static and 25 psi flow.</p> <p>See Digital Touch pad: Programming.</p>
	Auto fill power	<p>Verify that power is getting to the Auto Fill Solenoid.</p> <p>J8-FL Wire # 15 to neutral should be 120 V.</p>
Wash tank will not heat up	Water	<p>Confirm that water is in the tank.</p> <p>Low water protection component may be preventing the heaters or the gas burner from turning on.</p> <p>If there is water in the tank, the low Float Switch may need to be cleaned if it is not operating in the water.</p>

TROUBLESHOOTING TABLE FOR 10791 PC BOARD (CONTINUED)

PROBLEM	LIKELY SOURCE OF PROBLEM	CORRECTIVE PROCEDURES
Wash tank will not heat up (can't.)	Wash T-stat power	Verify that power is getting to the Wash T-stat. Power should be 120 V + 10 V from the PC board, J8-WT Wire.
	Wash contact coil power	Confirm that power is getting to the Wash contact coil. Power should be 120 V + 10 V from the T-stat Wire # 6.
	Heater circuit breaker	If the circuit breaker for the heaters has tripped, try to reset the breaker.
	Heater fuses	Check all heater fuses to see if any have blown.
	Gas heat	Refer to Gas Heating: Maxon or Infrared: Troubleshooting.
	LED	The LED for D-16 relay should be illuminated on the PC board.
Wash pump turns off during wash cycle.	Pump motor overload	If the pump motor overload is tripped, Error Code 07 appears on the touch pad. Try pressing the "Reset" button on the overload (the Blue Button located in the electrical panel). Check the Motor Starter (If available on the machine)
	Not enough water	If Error Code 03 appears on the touch pad, there is inadequate water in the machine. Put the water level below the Float Switch and refill the machine. Cycle the power on the touch pad off and then on. Machine should fill to proper level. If not, Fill Time needs to be reprogrammed. Refer to Digital Touch Pad: Programming

Troubleshooting Table for 10791 PC Board (Continued)

PROBLEM	LIKELY SOURCE OF PROBLEM	CORRECTIVE PROCEDURES
Wash pump turns off during wash cycle (cont.)	Door	Make sure the door is closed. When the Wash pump is started, the water pressure may be pushing against the door and causing the door switch to open. Error Code 06 would be shown on the touch pad.
Rinse tank will not heat up.	Heater circuit breaker	If the circuit breaker for the heaters has tripped, reset the breaker.
	Heater fuses	Check all fuses for the heaters to see if any have blown.
	Rinse T-stat power	Verify that power is getting to the Rinse T-stat. Recommended power is 120V + 10 V from J3-3 Wire # 14 on the PC board.
	Rinse contact power	Recommended power is 120 V + 10 V from T-stat Wire # 4. Note: Rinse tank should be full of water at all times.
	High limit disc	Check for continuity on High Limit Disc mounted to exterior. Of Rinse tank. Disc is normally closed and auto reset type

WATER LEVEL FLOAT SWITCH #1900 Low Water Float Switch

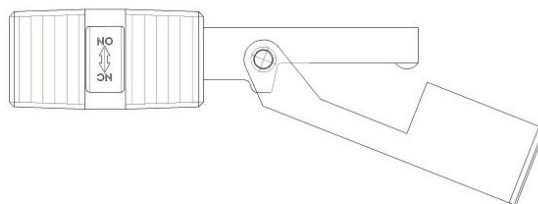

Float Switch Purpose- Low Water Protection Wash Tank



DOUGLAS
WASHING AND SANITIZING SYSTEMS

IMPORTANT NUMBERS

FOR WARRANTY WORK YOU MUST CALL DOUGLAS MACHINES CORP.
AT 800-331-6870 AND WE WILL ISSUE A
PURCHASE ORDER TO THE LOCAL SERVICE AGENT.

FOR PART OR TECHNICAL SUPPORT,
PLEASE CALL DOUGLAS MACHINES CORP. AT 800-331-6870

